

Unit 9 Test Review

Electric Circuits: Chapters 26-27

Multiple Choice Review: On this portion of the test, you will not be allowed to use your calculator or AP formula sheet. (You may, however, use your AP table of information.)
Approximate $g=10\text{m/s}^2$ for simplicity of calculations.
No partial credit will be given.

1. Two concentric circular loops of radii b and $2b$, made of the same type of wire, lie in the plane of the page, as shown above. If the total resistance of the b -radius loop is R , what is the resistance of the $2b$ -radius loop?

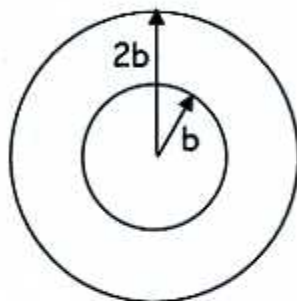

Note:
The diagram is not a cross-section!

- a. $R/4$
b. $R/2$
c. R

- d. $2R$
e. $4R$

$$R_b = \frac{\rho L}{A} = R$$

$$R_{2b} = \frac{\rho(2L)}{A} = 2R$$

2. How much does it cost to operate a 60W light bulb for 600 minutes, if energy costs 10 cents per kilowatt-hour?

- a. 6 cents
b. 10 cents
c. 36 cents

- d. 60 cents
e. $\$3.60$

$$\text{Energy} = (.06\text{kW})(10\text{h}) = 0.6\text{kWh}$$

$$\text{Cost} = (10 \frac{\text{¢}}{\text{kWh}})(0.6\text{kWh}) = 6 \text{ ¢}$$

3. Three resistors are connected as shown in the diagram. What is the electrical resistance of the part of the circuit shown?

- a. $4/3 \Omega$
b. 2Ω
c. $2 \frac{3}{4} \Omega$

- d. 4Ω
e. 6Ω

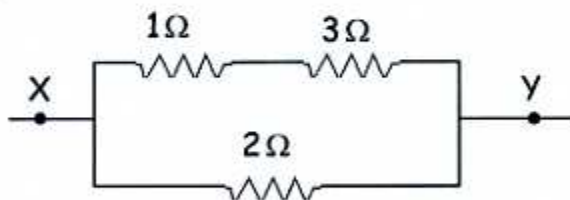

$$R = \left(\frac{1}{4} + \frac{1}{2}\right)^{-1} = \left(\frac{3}{4}\right)^{-1}$$

4. If the group of resistors in the previous problem is attached to a source of emf, the amount of charge passing a point per unit of time is...

- a. the same everywhere in the whole circuit.
b. greater at point X than at point Y.
c. greater in the 1Ω resistor than in the 2Ω resistor.
d. greater in the 1Ω resistor than in the 3Ω resistor.
e. greater in the 2Ω resistor than in the 3Ω resistor.

whatever current flows in through X must also flow out through Y. when this current splits into 2 branches, more flows through bottom because $2 \Omega < 4 \Omega$.

5. A wire of length L and radius r has a resistance R . What is the resistance of a second wire made from the same material that has length $L/2$ and radius $r/2$?
- a. $4R$ **b. $2R$** c. R d. $R/2$ e. $R/4$

$$R = \frac{\rho L}{\pi r^2} \quad R' = \frac{\rho (L/2)}{\pi (r/2)^2} = \left(\frac{1/2}{1/4}\right) \frac{\rho L}{\pi r^2} = 2R$$

6. Which of the following is NOT true about a circuit (containing a battery) with a 100W light bulb (resistor) connected in series with a 60W light bulb?

- a. If one bulb burns out, they'll both go out. \leftarrow True, since gap in circuit, & only 1 loop.
 b. The voltage across each bulb is different. \leftarrow True, since I is same while R different.
c. The equivalent resistance of the circuit is less than that of either bulb.
 d. The current in each bulb is the same. \leftarrow Always true for resistors in series.
 e. The 60W bulb is brighter than the 100W bulb. \leftarrow

This would be true for parallel.

True because "60W" refers to power rating across set voltage (parallel).
 In parallel, smaller R is brighter because $P = V^2/R$. In series, larger R is brighter since $P = I^2R$.

- Questions #7-9: In the circuit shown below, the emf's and the resistances have the values shown. The current I in the circuit is 2 amperes.

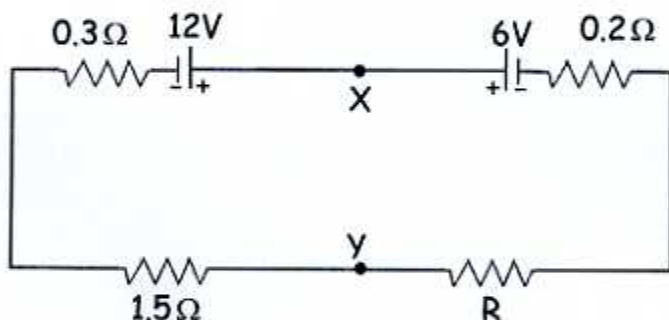

7. The resistance R is...

- a. 1Ω** b. 2Ω c. 3Ω d. 4Ω e. 6Ω

Loop Rule: $12 - 6 - 0.2(2) - 2R - 1.5(2) - 0.3(2) = 0$
 $2 - 2R = 0 \rightarrow R = 1\Omega$

8. The potential difference between points X and Y is...

- a. 1.2 V b. 6.0 V **c. 8.4 V** d. 10.8 V e. 12.2 V

Starting @ X: $V_x - 6 - (0.2)(2) - (1)(2) = V_y$ (Starting @ Y: $V_y - 1.5(2) - .3(2) + 12 = V_x$)
 $V_x - V_y = 8.4V$

9. How much energy is dissipated by the 1.5-ohm resistor in 60 seconds?

- a. 6 J b. 180 J **c. 360 J** d. 720 J e. 1440 J

$$P = I^2 R = (2^2)(1.5) = 6W$$

$$\text{Energy} = (6J/s)(60s) = 360J$$

10. A certain battery has an emf of 12V and internal resistance of 2Ω . If this battery is connected to a circuit in such a way that a current of 0.3A flows through the circuit, what is the terminal voltage of the battery?

a. 11.4V b. 11.7V c. 12V d. 12.3V e. 12.6V

$$V_{\text{obs}} = 12 - (0.3)(2) = 11.4$$

11. In the circuit shown to the right, the capacitor is initially uncharged. At time $t=0$, switch S is closed. The natural logarithmic base is e . Which of the following is true at time $t=RC$?

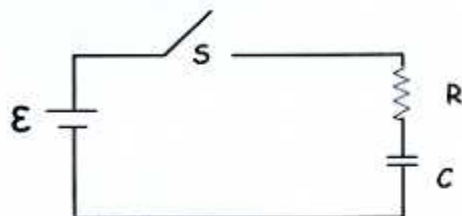

- a. The current is \mathcal{E}/eR .
 b. The current is \mathcal{E}/R .
 c. The voltage across the capacitor is \mathcal{E} .
 d. The voltage across the capacitor is \mathcal{E}/e .
 e. The voltages across the capacitor and resistor are equal.

Charging in general:

$$q = \mathcal{E}C(1 - e^{-t/RC})$$

$$V = \frac{q}{C} = \mathcal{E}(1 - e^{-t/RC})$$

$$I = \frac{dq}{dt} = \frac{\mathcal{E}}{R} e^{-t/RC}$$

so at $t=RC$...

$$V = \mathcal{E}(1 - e^{-1}) \quad I = \frac{\mathcal{E}}{R} (e^{-1}) = \frac{\mathcal{E}}{eR}$$

Problem Review: On this portion of the test, you may use your calculator, AP formula sheet, and AP table of information. Partial credit will be given on these problems.

12. A current of 15 A exists in a wire. How many seconds does it take for 8.0×10^{20} electrons to flow through a given cross section of the wire?

$$I = \frac{q}{t}$$

$$15 = \frac{(8.0 \times 10^{20})(1.6 \times 10^{-19})}{t}$$

$$t = 8.53 \text{ sec}$$

- 13a. How much resistance is present in a 240V generator dissipating 120 kW of power?

$$P = \frac{V^2}{R}$$

$$120,000 = \frac{240^2}{R}$$

$$R = 0.48 \Omega$$

- b. How much energy is dissipated by the resistance in the generator over the course of 4 minutes?

$$\text{Energy} = (120,000 \text{ W})(4 \times 60 \text{ s})$$

$$= 2.88 \times 10^7 \text{ J}$$

- 14a. Calculate the cross-sectional area of a 2.00cm length of tungsten filament in a small lightbulb if a potential difference of 120V sets up a current in it of 0.24A. (Tungsten's resistivity is $5.6 \times 10^{-8} \Omega \cdot \text{m}$.)

$$R = \frac{V}{I} \rightarrow \frac{120}{0.24} = \frac{(5.6 \times 10^{-8}) (.02)}{A} \rightarrow A = 2.24 \times 10^{-12} \text{ m}^2$$

- b. Calculate the current density in the filament.

$$J = \frac{I}{A} = \frac{0.24}{2.24 \times 10^{-12}} = 1.07 \times 10^{11} \frac{\text{A}}{\text{m}^2}$$

- c. Calculate the strength of the electric field in the filament.

$$E = V/d = \frac{120}{.02} = 6000 \text{ V/m} \quad E = \rho J = (5.6 \times 10^{-8}) (1.07 \times 10^{11}) \approx 6000 \frac{\text{V}}{\text{m}}$$

15. A 0.52A current exists in a copper wire whose diameter is 2.9mm. If the number of charge carriers per unit volume is $8.49 \times 10^{28} \text{ m}^{-3}$, calculate the drift velocity of the electrons in the copper wire.

$$I = Ne v_d A \rightarrow 0.52 = (8.49 \times 10^{28}) (1.6 \times 10^{-19}) (v_d) (\pi (\frac{0.0029}{2})^2) \rightarrow v_d = 5.8 \times 10^{-6} \text{ m/s}$$

16. Use the rules for resistors connected in parallel and series (not Kirchoff's rules) to calculate the current through the 5Ω resistor in the figure, when the complex circuit is attached to a 12V battery.

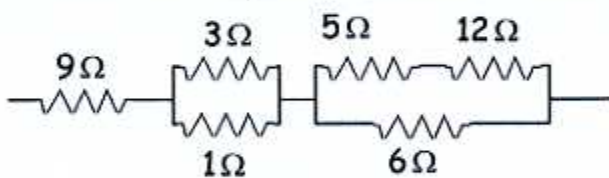

$$I_5 = 0.22 \text{ A}$$



$$I_{17} = \frac{3.75}{17} = 0.22 \text{ A}$$

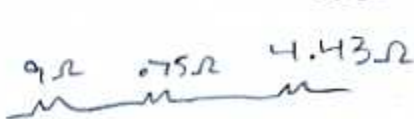

$$V_{4.43} = (.85)(4.43) = 3.75 \text{ V}$$

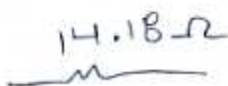

$$I = \frac{12}{14.18} = 0.85 \text{ A}$$

17. Use Kirchoff's rules to find the size and direction of the current through R_1 , and also the potential at point X. (Remember that I'm choosing directions of currents arbitrarily.)

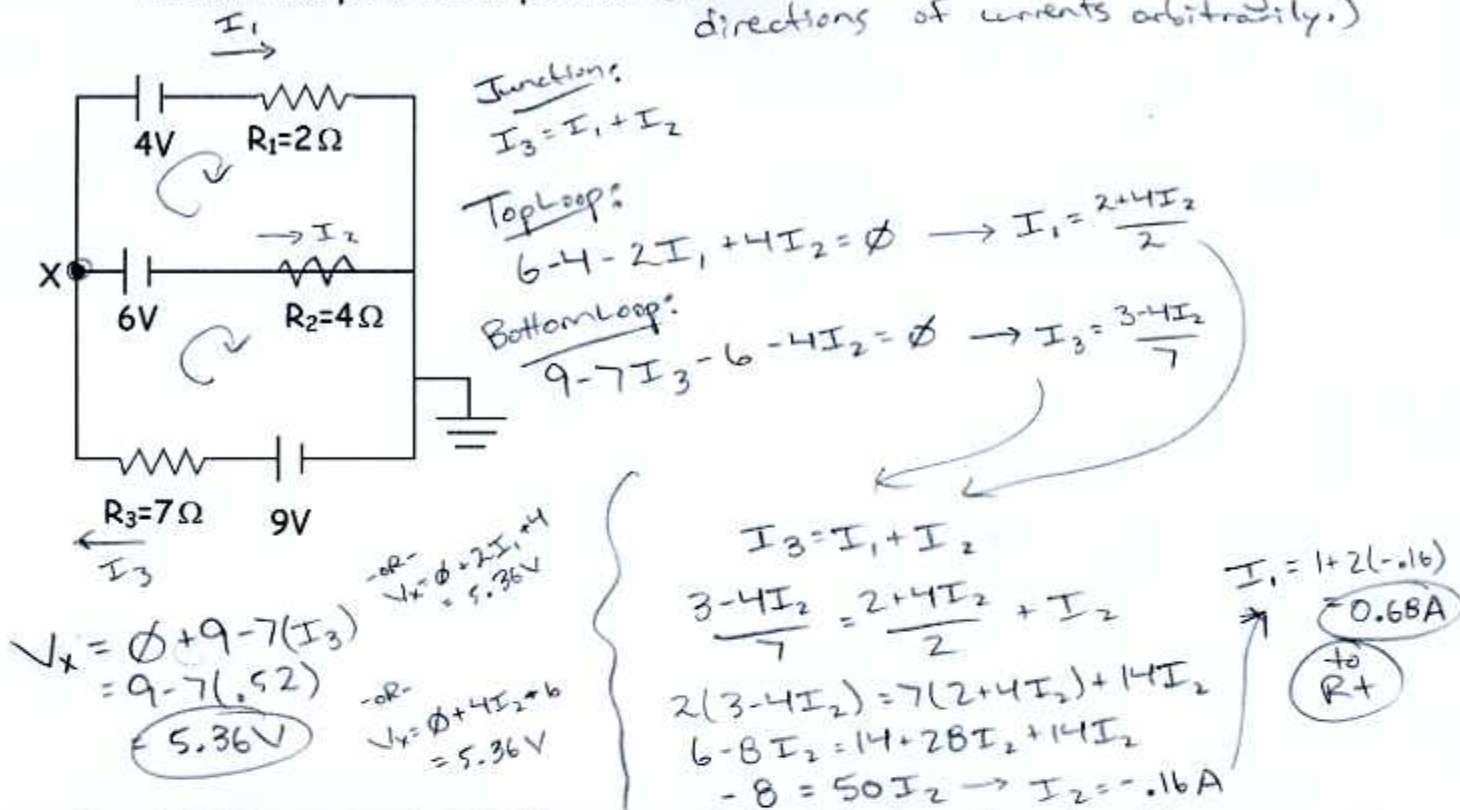

18. A 35nF capacitor is initially uncharged when it is placed in series with a 200MΩ resistor.

- a. When the resistor-capacitor combination is connected across a 12V battery, how much time is required for the potential difference across the capacitor to reach 9V?

charging:
 $V = \mathcal{E}(1 - e^{-t/RC})$
 $9 = 12(1 - e^{-t/(35n(200M))})$

$e^{-t/7} = .25$
 $-t/7 = \ln(.25)$
 $t = 9.7s$

- b. How much charge is stored in the capacitor at that time?

$q = \mathcal{E}C(1 - e^{-t/RC})$ -or- $q = VC = (9)(35nF) = 315nC$

- c. The capacitor is allowed to charge fully, and then the battery is removed at time $t=0$. What is the charge stored by the capacitor at time $t=4.2\mu s$?

charge fully: $q = \mathcal{E}C = (12)(35nF) = 420nC$

Discharge: $q = q_0(e^{-t/RC})$
 $q = (420nC)(e^{-\frac{4.2}{7}})$
 $= 230.5nC$

19. The circuit in the given figure is constructed with C initially uncharged. The switch is closed at time $t=0$.

- a. At time $t=0$, find the current through both resistors.

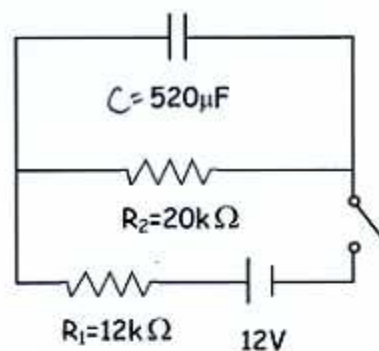

The capacitor initially behaves like a short-circuit or wire, so no charge will tend to flow through R_2 initially.

$$I_2 = 0$$

$$I_1 = \frac{12}{12,000} = .001\text{ A}$$

- b. At time $t=\infty$, find the current through both resistors.

The capacitor, once fully charged, behaves as a gap in the circuit, so no charge will flow through its branch.

$$I_1 = I_2 = \frac{12}{(12,000 + 20,000)} = 3.75 \times 10^{-4}\text{ A}$$

- c. Find the final charge on the capacitor.

$$Q_{\text{full}} = CV_c = (520 \times 10^{-6}) (7.5) = .0039\text{ C}$$

$$V_c = V_2 = I_2 R_2 = (3.75 \times 10^{-4}) (20,000) = 7.5\text{ V}$$

